

Future Wireless Networks— Evolution and Challenges

Stephen Weinstein

Communication Theory & Technology Consultants, and Adjunct Prof. EE, Columbia University, USA

ABSTRACT

This broad perspective on future wireless networks derives from a plenary talk at the IEEE 6th Circuits and Systems Symposium on Emerging Technologies: Frontiers of Mobile and Wireless Communication (MWC 2004), held in Shanghai May 31-June 2, 2004. It is my personal view of interesting topics along the way to an integrated wireless access environment, encompassing cellular mobile, WiFi, WiMax, UWB and other systems, that may become the definition of “4th generation” rather than a narrowly defined new cellular mobile system. Architectures and technologies common to the different access systems make this a credible scenario, and services integration is already happening. This article identifies some of the research, development, and business model challenges.

DIVERSITY AND CONVERGENCE

Wireless networking, the healthiest segment of the communications industry, continues to generate new types, features, and services day by day. Until recently cellular mobile and WiFi (IEEE 802.11) were the only well-deployed systems, and they were quite separate in architecture, range and function. Cellular mobile, relying on a large number of base stations connected via dedicated or switched facilities to mobile switching centers, was almost entirely used for public voice communication over wide geographical areas. The same level of QoS (quality of service) was presumed, if not always delivered, over the entire service area. The Internet was a separate entity reached (if at all) through gateways. WiFi, in contrast, covered small indoor areas in private networks for local data communication and Internet access. Data rate was (and remains) non-uniform, depending on distance from the access point. The routers that are packaged with WiFi access points were and are part of the Internet. Voice was unknown but media streaming had begun, for online radio broadcasting (still point-to-point) and peer-to-peer media exchanges, soon to be constrained by the music industry in defense of intellectual property

rights.

There is a different situation today. Cellular mobile systems now provide access to Internet services such as email, (limited) web browsing, and transmission of pictures and short video clips from camera-equipped handsets. Third-generation cellular mobile assigns equal emphasis to voice and data traffic. Cellular systems envision IP (Internet Protocol) backbones rather than dedicated or switched facilities, effectively making cellular mobile networks part of the Internet (although not necessarily shared with other users). WiFi’s rapid deployment and performance increases are beginning to support streaming media including VoIP (voice over IP), and there are many WiFi public access services. WiMax (IEEE 802.16) is beginning an evolution from very large cell, very high rate fixed wireless to a kind of large-cell high-rate access system supporting some degree of mobility.

UWB (Ultra Wideband) is a new contender for very high speed media-oriented home networking and for many other applications, possibly on a metropolitan area scale. By overlaying a very wide, low-power-density spectrum over existing services, it is a way of growing capacity without dedicating new spectrum. Bluetooth for the personal area network is reaching for higher data rates, and Zigbee is an initiative toward a very low-cost, low-power technology for devices such as peripherals, toys, and active RF tags [www.zigbee.org]. Figure 1 suggests this diverse but increasingly interconnected environment.

In addition to the growing convergence toward IP appliances, an IP backbone, and overlap of services suggested above, many of the current and future wireless networks (4G cellular mobile, WiMax, IEEE 802.11a, multiband UWB) employ OFDM (orthogonal frequency division multiplexing), which efficiently generates multiple transmission channels by computational processing using the discrete Fourier transform. This common feature may make it easier to provide multiple-air-interface appliances in support of a smoothly integrated 4G environment.

In response to all of these integrating and cross-services trends, network operators perceive an

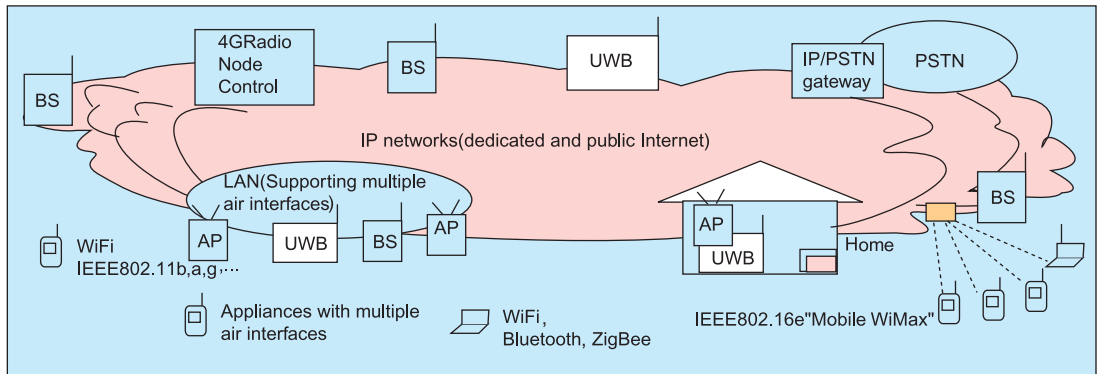

Fig. 1. Elements of the evolving wireless access environment

integrated wireless business in which various appliances (handsets, media players, etc.) move seamlessly – at least with minimal disruption – across the boundaries between the different access systems with billing through one provider. Chip sets supporting multiple air interfaces are already manufactured, and the future may bring cost-effective software-defined radio. Some cellular operators already own public access WiFi businesses and the likelihood of full integration is high.

Finally, wireless communications is vital for emergency communications, filling gaps, locating people and services, and overlaying parts of the vulnerable wired infrastructure. Ad-hoc networking and location-based services are important components of the future wireless environment.

Briefly summarizing and extending this discussion, some of the more important elements contributing to the future wireless environment are:

- Access diversity (cellular mobile, WiFi, WiMax, UWB, Bluetooth, Zigbee, ...)
- Wireless Internet (broadband Internet access and media QoS)
- Gains in rates, spectrum utilization, and spectral efficiency (bits/sec/Hz)
 - Space-time-frequency coding
 - MIMO (multiple transmitting and receiving antennas)
 - “Cognitive radio” to better share spectrum/time resources
 - Interference cancellation
 - OFDM (orthogonal frequency division multiplexing)
- Resilience and Emergency Services
 - Exploiting diversity and overlays
 - Ad-hoc networking
 - Better coordination of emergency networks
 - Integration strategies
 - Multiple air interface devices and networks
 - Interoperating cellular mobile/WLAN/WPAN systems
 - Powering
 - Power-sensitive processing
 - New or improved battery technologies
 - Networked applications

- Web-based services
- Application and data synchronization
- QoS mappings across multiple networks and protocol levels
- New business models
 - Services/billing integration across diverse access networks
- Public access WLANs
- Virtual operators

WHAT'S HAPPENING WITH THESE ELEMENTS

It would be a long article indeed that gave a comprehensive explanation of the progress and obstacles for each of the above topics. This article offers only a few brief observations and opinions on aspects that are particularly interesting to me.

The previous section introduced wireless access diversity, with “access” understood to mean access to the Internet or to dedicated IP backbone networks. The wireless Internet, like the Internet as a whole, will require efficient IP mobility, i.e. traffic taking the best route, not necessarily through a home location, and local mobility to minimize wide-area location-updating traffic. It will support media streaming services (including VoIP) that map QoS across the wired/wireless network boundary. It will maintain data synchronization through periods of connection and disconnection and supplement the limited processing capabilities of portable devices with Web-based services. Figure 2 illustrates a music video streaming application across the WiFi air interface, with the audio/video stream efficiently routed to the user and QoS mapped from the wired Internet (perhaps using DiffServ's Expedited Forwarding) and the air interface (perhaps using a low-latency backoff when collisions occur). This figure also suggests an interesting IP appliance of the future: a true heads-up see-through display in ordinary prescription eyeglasses. Dangerous? Perhaps, but fighter pilots already use heads-up displays.

The new technologies for making better use of the available spectrum may save 3G cellular mobile

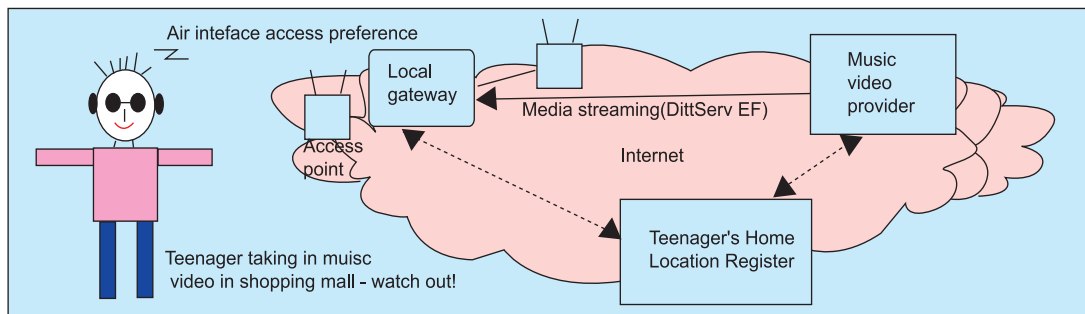

Fig. 2. Streaming a music video through the wireless Internet.

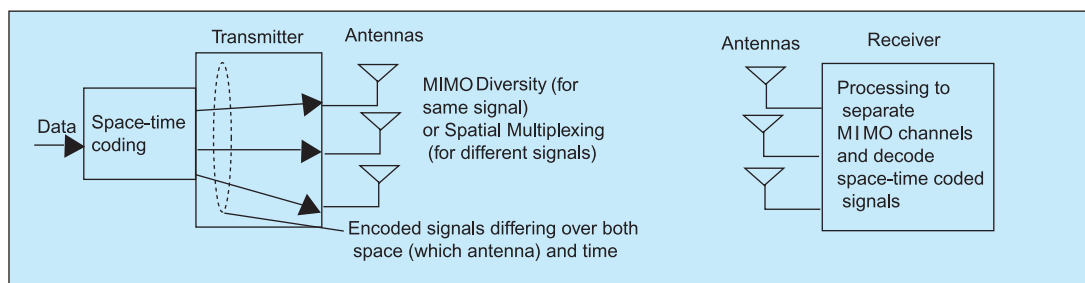

Fig. 3. Definitions of space-time coding and MIMO.

from an overpricing disaster. By clever coding of transmitted signals over both space (different antennas) and time, channel impairments become much less formidable. MIMO (multiple transmitting and receiving antennas) is a related technique [1] for achieving either diversity (the objective of coding over space) or gain in information rates (by sending different data streams over essentially uncorrelated radio channels). The number of essentially uncorrelated radio channels is roughly the same as the number of transmitting antennas, if the antennas are adequately separated, which appears possible for three or four antennas even on a telephone handset. Spectral efficiencies tens or hundreds of times larger than with use of single antennas are at least theoretically possible. Figure 3 may help to clarify the definitions of space-time coding and MIMO.

One of the challenges for using these technologies is reduction of implementation complexity for high-performance systems with large numbers of antennas and high-rate space-time coding. There are promising approaches such as spherical detection for MIMO [4], space-time turbo coding [2] and breaking the complexity of a 4-antenna space-time coding system into two simpler 2-antenna space-time codes [3], as well as optimization of linear transmit/receive filters [6].

Coordinated control of multiple transmitting antennas also has potential for cancellation of interference. One application, illustrated in Figure 4, is use of short-range radio, such as WiFi, to replace cable drops in an HFC (hybrid fiber/coax) access system. In this design [7], densely deployed access points (antennas) on a coax line supply multiple users with high, dynamically-changeable rates, without mutual interference even in the same channels.

Orthogonal delivery channels are defined by the appropriate antenna excitations.

Reducing wasteful underuse of parts of the radio spectrum underlies the cognitive radio initiative of the U.S.'s FCC (Federal Communications Commission) [www.fcc.gov/oet/cognitiveradio/]. During a particular time period, a cognitive wireless appliance senses and adapts its power and signaling to whatever spectrum (and its signaling formats) that is available, avoiding interference with other users. It moves from time to time to other unused time/frequency slots as illustrated in Figure 5. In addition to technology advances, a new spectrum market system must be devised to make this economically feasible.

Resilience and emergency services relies on diversity and overlays, ad-hoc networking, better coordination of emergency networks, and location-based services (using triangulation among base stations or the satellite GPS (Global Positioning System)). One interesting possibility, still a research topic, is a metropolitan-scale WLAN overlay, i.e. an ad-hoc network of WLAN access points supporting both regular and emergency traffic when parts of the wired public infrastructure are inoperative or overloaded. Connections to the wired backbone are made where they are available, as shown in Figure 6. This concept also illustrates the transition of IEEE 802.11 WLAN, as access points proliferate from a short-range indoor access technology to a technology of wide-area access through ubiquitous hot spots.

More generally, ad-hoc networks will see more use for emergency communication among appliances (handsets, cameras, environmental monitors, small computers) used by emergency personnel. Recent testimony before the 9/11 Commission in the United

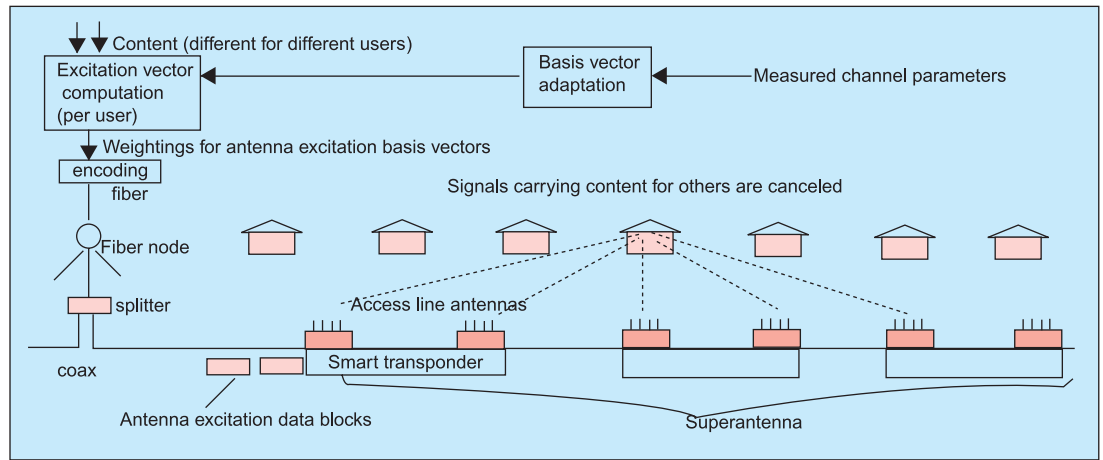

Fig. 4. Dense wireless access system that cancels mutual interference.

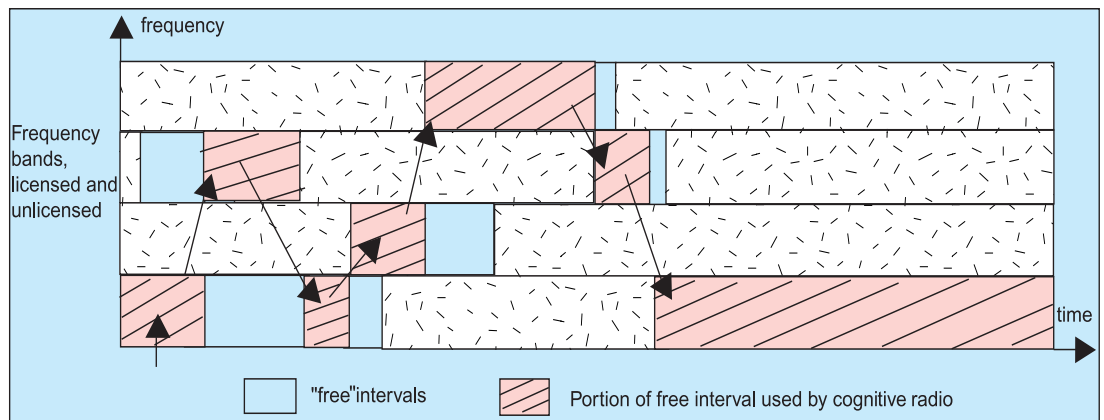

Fig. 5. Cognitive radio: an appliance uses available time-frequency slots.

States described inadequate communication between police and fire department personnel during the attack on the World Trade Center in 2001. IP-based appliances are beginning to appear with the capability to self-organize networks at emergency sites and monitor environmental and physiological signals [www.mobilemag.com/content/100/340/C2782/]. These appliances will need special processors, buffers and contention resolution mechanisms for traffic relayed through the appliance, and adequate powering, all challenges for equipment developers. The greatest challenge, perhaps, is finding civilian uses for these capabilities to make their added cost economically feasible in mass-produced devices.

Ad hoc sensor networks, relaying many kinds of environmental and system information are expected to become as important as interpersonal and user service communications in the future. Sensor networks may include geophysical and weather monitors, performance monitoring devices on machines in factories and power plants, and, of course, networks reading RFIDs (very small, inexpensive tags, active or passive) on products of many kinds. Although I enjoy using the EZ Pass RFID device in my car to pay highway tolls, I believe we should hesitate before building vast sensor

networks that may track every movement of an individual human being.

One interesting possibility for ad-hoc networks is to exploit devices with multiple air interfaces to increase the density of relay links. Figure 7 illustrates such a network, with devices that may, for example, have either a WiFi interface, a Bluetooth interface, or both. Current efforts to resolve interference between WiFi and Bluetooth devices will encourage this possibility.

Even without introducing ad-hoc networking, interoperation of cellular mobile, WiFi, WiMax, UWB, Bluetooth, Zigbee (and whatever else will appear in the future!) is important for both network resilience (resistance to damage and dropouts) and consumer convenience. It raises many technical and business model challenges, including economical multi-service devices, integrated AAA (access, authorization, accounting), and accommodating, in both pricing and services, a dynamic range of available access rates rather than the uniform rates of the cellular mobile network.

Fortunately, services control may be abstracted from the particular physical network being used. One illustration is the "virtual operator" model, a step beyond roaming, in which multiple service providers

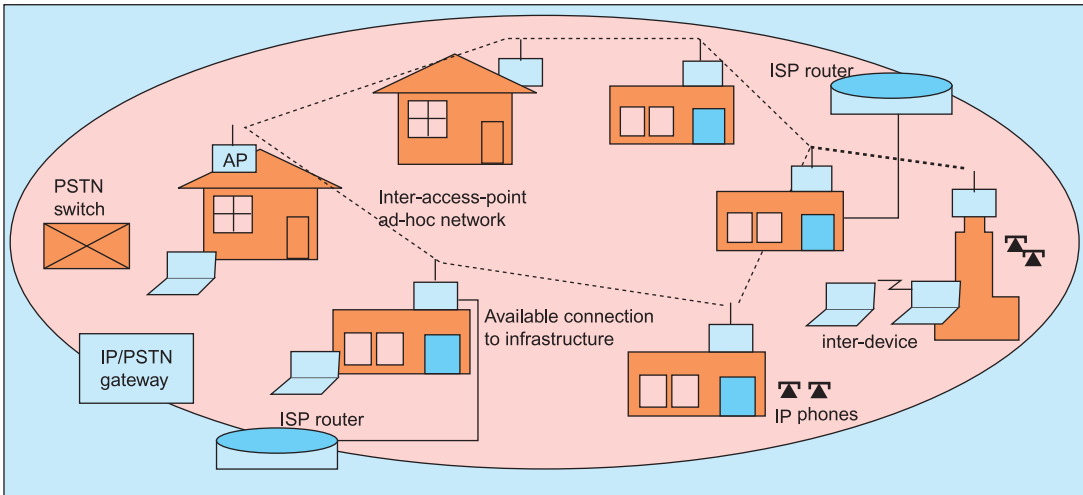

Fig. 6. Ad-hoc WLAN overlay on the wired (and cellular mobile) metropolitan area networks.

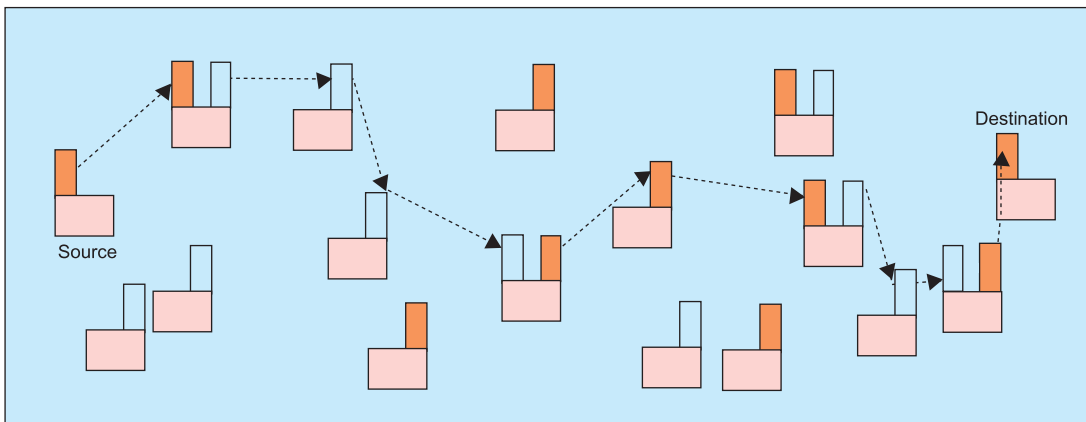

Fig. 7. A path in an ad-hoc network in which some devices use WiFi, some Bluetooth, and some both (hopefully at the same time).

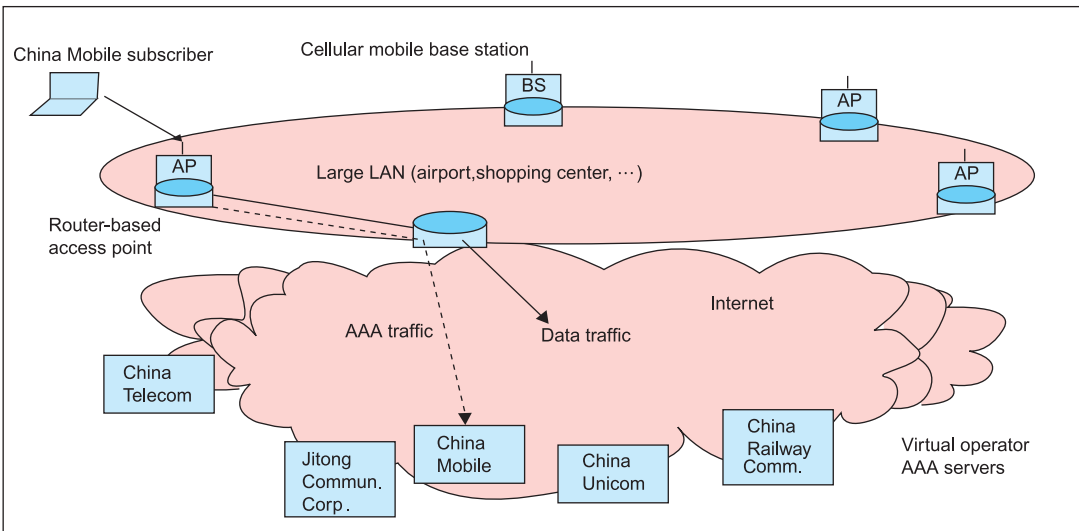

Fig. 8. Multiple virtual operators within the same physical network.

may, to their customers, be the effective service operator within a network that is actually operated by someone else and differs from the "home" network. Different service menus could be offered to the customers of different virtual operators. Figure 8 illustrates this concept for a WiFi installation in a large environment such as an airport or shopping center, with AAA carried out at the network (IP) level with a distant virtual operator server [5].

The business models for future wireless services are not as sure as they were when cellular mobile was the only public service. In addition to the franchised WiFi chains, we are already seeing an explosion of small WISPs (wireless Internet service providers) who provide WiFi access for free from their homes, small shops, or public institutions such as libraries. The cable data and DSL ISPs to which the small WISPs are connected are not happy about admitting additional nonpaying users, and sooner or later there will be a reasonable business model for modest fees split between the access providers and the WISP operators.

Battery power for multifunctional, processing-intensive devices, with long intervals between charges, is a never-ending challenge. A combination of approaches must be considered, such as putting complex audio/video decoders to sleep during inactive periods, using very low power VLSI, and developing new, denser forms of energy storage. The hydrogen cell sometimes proposed for future automobiles may appear first in high-performance wireless appliances.

WHAT TO DO?

Fortunately for those of us who make our living from communications research, development, and services delivery many interesting projects and business ideas remain to be invented and pursued. The ideas in this article, and hundreds of others not reported here, show that our field is still young and growing. One important thing to bear in mind is that the proportion of individual and corporate income devoted to communications will not increase indefinitely. Communications can and must be the stimulus for the entire world economy to grow rapidly, making our industry prosper along with others.

REFERENCES

- [1] H.Boelcskei, "Space-Time Coding & Signal Processing for MIMO Wireless", course offered by Prof.Helmut Boelcskei, ETH Zurich, Oct. 2002.
- [2] C.Chen & H. Haimovich, "Low complexity MIMO layered Turbo Space-Time Coding", www-ec.njit.edu/~haimovic/publication/ChenHaimovichISWC02.pdf
- [3] R.Blum, Y.Li, J.Winters, Q.Yan, "Improved space-time coding for MIMO-OFDM Wireless Communications", *IEEE Trans. Commun.*, Nov. 2001
- [4] T.Kailath, "Maximum Likelihood Detection in Gaussian Channels Can Have Polynomial Complexity", keynote address at MWC 2004, and H.Vikalo and B.Hassibi, *Sphere Decoding Algorithms for Communications*, expected 2004 (Cambridge University Press).
- [5] J.Li, S.Weinstein, J.Zhang & N.Tu, "Public Access Mobility LAN: Extending the wireless Internet into the LAN environment", *IEEE Wireless Magazine*, Jun. 2002.
- [6] J.Nossek, M.Johan & W.Utschick, "Transmit Processing in MIMO Wireless Systems", *Proc. IEEE MWC 2004*, May 31-June 2, 2004.
- [7] S.Weinstein & J.Lechleider, "Multi-user wireless access to a digital cable system", *Proc. WCNC 2004*, Mar. 2004.

BIOGRAPHY

*Dr. Stephen B. Weinstein, who considers himself "semi-retired", is a consultant (www.cttcservices.com) and adjunct professor of Electrical Engineering at Columbia University. His long career included employment by Philips Research Labs, Bell Labs, American Express, Bellcore (Telcordia), and NEC. He made basic contributions to OFDM, modem technologies, and broadband communication. He is coauthor of the textbook *Data Communication Principles* (Plenum 1992), the light technical *Getting the Picture: A Guide to CATV and the New Electronic Media* (IEEE Press, 1984) and (in preparation) *The Multimedia Internet, a light technical survey of communications, media compression, and Internet media protocols and technologies*. He is a past President of the IEEE Communications Society (1996-97) and past Member of the IEEE Board of Directors (2002-2003).*